

- Series 507 SMT Headers “float” in a machined epoxy insulator.
- Series 513 Interstitial PGA surface mount sockets are available with and without tabs for clip-on heatsinks.
- Mill-Max #43, “Ultra-Lite” contact standard, see page 209 for details.
- Hi-Temp PCT polyester insulator material suitable for all forms of soldering.

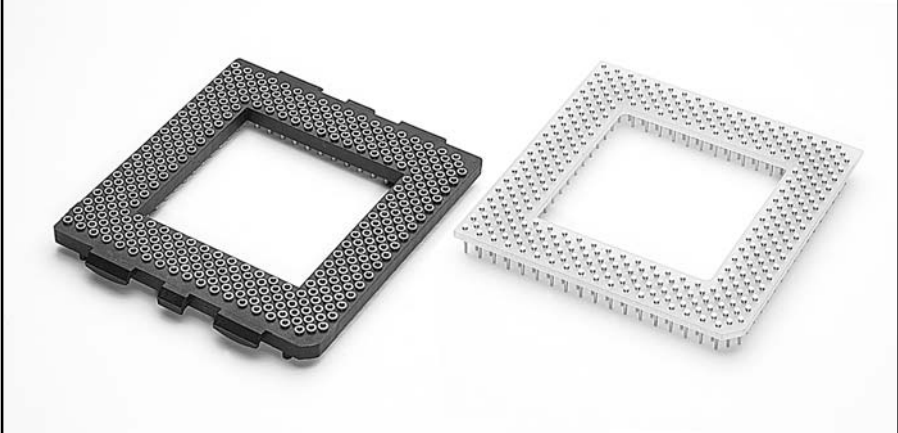

Ordering Information

HEADER PIN TYPE 0737

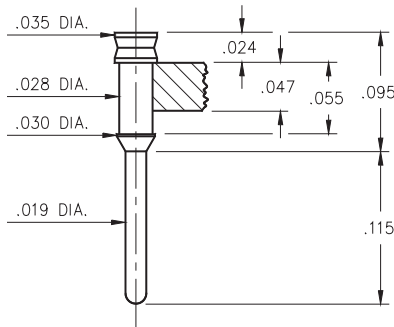

FOR PGA MALE HEADER

1. Locate footprint pattern from pages 107 to 111, the middle 8 digits of the part number will be located under the pattern.

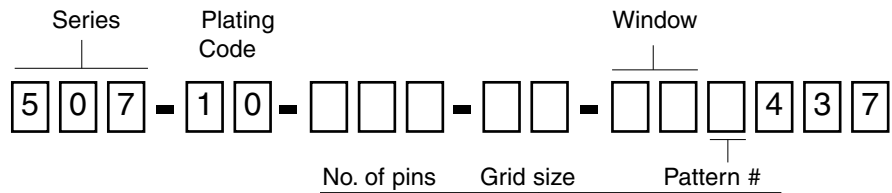

Determined from footprint pattern pages 107 to 111

SPECIFY PLATING CODE XX=	10◇			
Pin Plating	10μ" Au			

SMT RECEPTACLE TYPE 1385

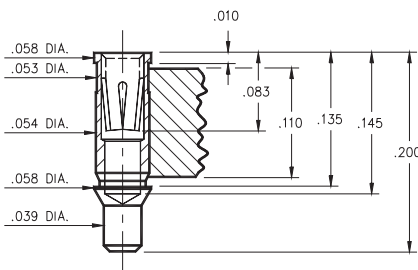

FOR PGA FEMALE SOCKET

1. Specify 2-digit plating code from chart at bottom of page.
2. Locate footprint pattern from pages 107 to 111, the middle 8 digits of the part number will be located under the pattern.

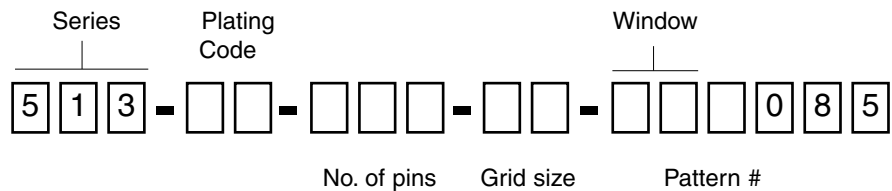

Determined from footprint pattern pages 107 to 111

SPECIFY PLATING CODE XX=	13◇	93		43◇
Sleeve (Pin)	10μ" Au	200μ" Sn/Pb		200μ" Sn
Contact (Clip)	30μ" Au	30μ" Au		30μ" Au